

## 1 INFORMATION ON THIS DOCUMENT

### 1.1 Function

The present instruction sheet provides information on installation, connection and safe use of the NG series safety switch having an interlocking function with or without protection block, according to the EN ISO 14119 standard.

### 1.2 Addressed to: qualified personnel only

The operations you find explained in the present instruction sheet must exclusively be carried out by qualified personnel, who are perfectly able to understand them and have been duly authorised.

### 1.3 Field of application

These instructions apply only to the NG series and its accessories.

## 2 SYMBOLS USED

 This symbol indicates any relevant complementary information.

 Warning: Any failure to observe this warning note can cause breakage or malfunction, with possible loss of the safety function.

## 3 FITTING INSTRUCTIONS

### 3.1 Choosing the type of actuator

 **Warning:** The switch is available with two types of RFID actuator: one with a high coding level (F31) and one with a low coding level (F30). In the case where an actuator with a low coding level has been chosen, ensure that the additional specifications prescribed in paragraph 7.2 of the EN ISO 14119:2013 standard are respected during installation. Moreover, any other F30 actuators present in the same place where the switch has been installed must be segregated and kept under strict control in order to avoid any elusion of the safety device.

 It is advisable to use actuators with a high coding level so as to make the installation safer and more flexible. This will render it unnecessary to screen the device, to fit it in non-accessible areas or to follow other prescriptions specified by the EN ISO 14119 standard for actuators with low coding level.

### 3.2 Choosing the operating principle

 **Warning:** The switch is available with two operation principles:  
Operation principle D = Actuator locked with electromagnet de-energised (spring lock, release with I4 input activation).  
Operation principle E = Actuator locked with electromagnet energised (lock with I4 input activation, spring release).  
Operation principle D keeps the door lock even in the case where the machine is disconnected from the power supply. Therefore, if the machine is subject to dangerous movements with inertia, all dangerous elements are made fully inaccessible (door locked) even in case of sudden power failure. On the contrary, if the machine structure allows a person to enter the danger area with the whole body and possibly end up being stuck inside the machine, the switch must be provided with an anti-panic release button, in order to allow the trapped person to get out even in case of power failure.  
Operation principle E keeps the door lock only when the machine is connected to the power supply. Therefore, before choosing this operation principle, carefully evaluate all dangers deriving from sudden power failure with a consequent possible immediate door release.

 In case of machines without inertia, i.e. with dangerous elements being immediately locked as soon as the protection is opened, for which a door-lock switch has been chosen merely to safeguard the production process, operation principle D or E can be used indifferently.

### 3.3 Choosing the safety output activation mode

Warning: The switch is available with two safety output activation mode:

- Mode 1 (NG .....1...): safety output active on guard closed and locked
- Mode 2 (NG .....2...): safety output active on guard closed.

When the switch and the actuator are correctly mounted on the guard, a Mode 1 switch will activate safety output OSSDs when the guard is both closed and the locking bolt is in the locked position, so the guard cannot be opened with safety outputs on. Mode 1 device is a coded type 4 guard locking with lock following EN ISO 14119. When the switch and the actuator are correctly mounted on the guard, a Mode 2 switch will activate safety output OSSDs when the guard is closed. This mode allows to lock/unlock the guard while still keeping on the safety chain, typically for specific applications without inertia, when the risk does not continue after the opening of the guard. Care must be taken to evaluate if Mode 2 could be applied safely to the machinery to be protected: Mode 2 device is a high coded type 4 guard locking without lock following EN ISO 14119.

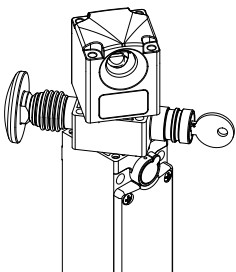

### 3.4 Device adjustment

If necessary, it is possible to adjust the position of the head and the release device (if present) in order to turn the device to the most appropriate position for the specific application. Fully remove the 4 screws from the head to turn either the head or the release device independently over an arc of 270°.

 **Warning:** Do not force the rotation beyond 270°, otherwise the device could be broken.

Once the adjustment has been completed, newly tighten the head screws with a torque from 0.8 to 1.2 Nm.

 **Warning:** In order to implement Safety function number 4 (see par. 4.1) after head adjustment it is mandatory to fasten the two provided one-way screws in place of two original screws, in opposite corner positions.

### 3.5 Device adjustment

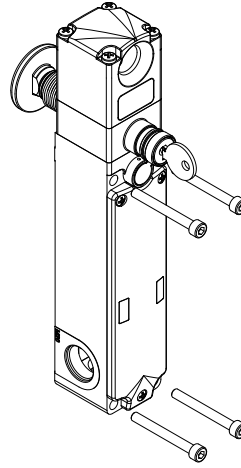



 **Attention:** Once adjustment is complete, re-tighten the head screws with a torque between 0.8 and 1.2 Nm.

 **Warning:** The device must be fixed to the machine by means of 4 M5 screws with a length of 45 mm or more. The device must never be fixed with less than 4 screws. The 4 screws chosen for fixing must be able to withstand a pull greater than 20,000 N exerted on the actuator. Tightening torque of the 4 M5 screws from 2 ... 3 Nm

 It is advisable to install the device in the top part of the door, in order to prevent any dirt or work residues from getting inside the hole where the actuator is to be introduced. In order to avoid device bypassing it is advisable to fix the device to the machine body with non-removable fastening

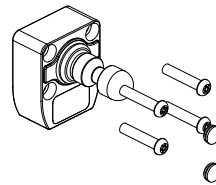
### 3.6 Fixing the actuator to the door



 **Warning:** As prescribed by the ISO14119 standard, the actuator must be fixed to the door frame irremovably.

For this purpose the actuator is provided with 4 safety screws. After the fixing operation, it is mandatory to plug the holes of the 4 screws using the caps supplied, so that it becomes more difficult to access the screws.

The actuator must always be fixed using at least 4 M5 screws with a length of 20 mm or more. The actuator must never be fixed with less than 4 screws. The 4 screws chosen for fixing (if different from those supplied) must be able to withstand a pull greater than 20,000 N exerted on the actuator. Tightening torque of the 4 M5 screws = 2 ... 3 Nm

 For correct fixing, other means can also be used, such as rivets, non-removable one-way security screws or other equivalent fixing system, as long as they are able to withstand a pulling force greater than 20,000 N.

### 3.7 Switch-actuator alignment

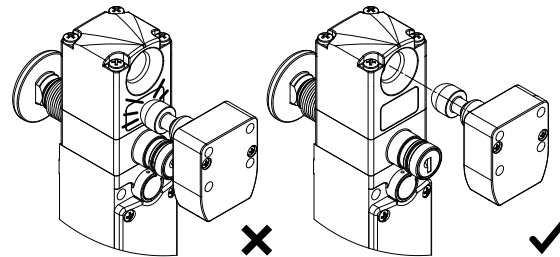

 **Warning:** Despite the fact that the device has been designed to help alignment between the head and the respective actuator, excessive misalignment could cause the actuator to be damaged. Periodically check the alignment between the switch and the respective actuator.

Maximum misalignment permitted from the hole axis, for rigid doors: +/-2 mm vertical and horizontal.

The actuator must not knock on the outside of the actuator inlet area, and must not be used as a centering device for the mobile protection.

In the case of application on swing doors, check that the radius between the axis of the actuator pin and the axis of the hinge fitted on the door is greater than 150 mm. Do not use a hammer for the adjustments, unscrew the screws and adjust the device manually, then tighten it in position.

This device is not suitable for applications in which the guard, with the permanently attached actuator, allows misalignments such as the actuator shaft does not enter through the hole of the device head with the door completely closed.

 The switch is provided with a through hole for inserting the actuator. In the case where it is used in dusty places, make sure not to obstruct the outlet hole opposite the inlet one. This way, any dust which may go inside the hole will always be allowed to come out of the opposite side.

### 3.8 Anti-panic release button

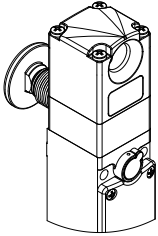

Some of the switch versions are provided with a release button in order to allow any personnel accidentally trapped inside the machine to get out. This button, complying with the EN ISO 14119 standard, directly acts on the lock mechanism, and immediately releases the actuator regardless of the condition in which the device is found. Moreover, after being activated, this button causes immediate opening of the OS1 and OS2 outputs in mode 1 switch and the O4 signalling output. This button unlocks the door even if the device is not supplied with power.

For correct installation of the anti-panic release button, the following prescriptions are to be observed:

- The release button must be clearly visible from inside the machine
- Button activation must be easy, immediate and unrelated to the machine operating status. To help recognise the button and make its function evident, identification stickers are available in various languages. Contact our commercial organisation (see SUPPORT paragraph).
- The release button must not be made easy to activate by an operator standing outside the machine, when the door is closed.
- To guarantee correct operation and handy resetting, a distance ranging from 10 to 35 mm must be kept between the wall from where the button protrudes and the release button.
- The release button sliding area is to be kept clean. Any dirt or chemical substance getting inside the button could compromise device operation.
- Check the button periodically (at least once a year) for correct operation.
- Train the personnel concerned on correct button operation, so as to avoid any improper use (i.e. the button must not be used as a clothes-hook).
- The release button must not be used as a machine emergency stop.

For installation on walls thicker than 20 mm, extensions are available for the release button.

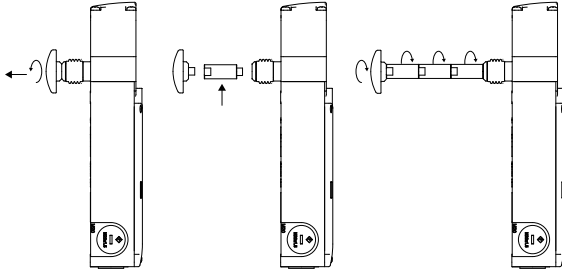

For correct installation of the extensions, observe the following prescriptions:

- Do not exceed an overall length of 500 mm between the release button and the switch.
- Always use some thread locker on each threaded coupling between the button, extensions and switch.
- Avoid twisting or bending the release button, if necessary use an appropriate sliding guide (pipe or bush) when the button and its extensions exceed a length of 100 mm.
- Tightening torque for button and extensions from 4 to 5 Nm.

### 3.9 Access control

These switches alone cannot manage to protect any operators or maintenance engineers in the case where they may physically enter the danger area with their whole body, since any unintentional closing of a protection behind them could allow the machine to be restarted. In the case where machine restarting control is entirely entrusted to these switches, a device must be provided to avoid the said risk, such as for example a lock-out system which stops the machine from being restarted. A specific lock-out device is available as an accessory so as to prevent any unintended start of the machine with the operator still inside, please contact our commercial department (see SUPPORT paragraph).

### 3.10 Auxiliary release with a tool or a lock

Some of the switch versions are provided with an auxiliary release in order to allow handy installation (release with a tool) or to permit opening only for authorised personnel (lock release). Both these mechanical devices act inside the switch like the anti-panic release button described previously. Therefore they also unlock the door in case of power failure. These release devices may only be operated by a machine maintenance engineer who has received adequate training on the dangers deriving from their use.

How to use the auxiliary release with a tool:

- Unscrew the locking screw with a PH1 cross-head screwdriver.
- Turn the hexagonal-hole bush clockwise by 180°.
- Do not force the bush beyond 180°.
- To avoid any improper use of the auxiliary device with a tool, it is advisable to seal the device through the appropriate hole found in the upper part, or to seal the screw cross head with a few drops of paint.
- After each activating operation, it is advisable to reseal the device.
- For particular applications, versions are available entirely free of any auxiliary release device.

How to use the auxiliary lock release:

- Open the protection cap.
- Insert the key supplied with the switch and turn clockwise by 180°.
- Do not force the key beyond 180°.
- Each time the key is extracted, close the rubber cap.
- The release key must only be made available to the machine maintenance engineer

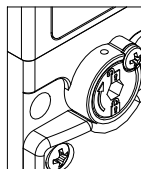

and kept in a secluded place.

- The release key must not be made available to the machine operator.
- For particular applications, versions are available entirely free of any auxiliary release device.

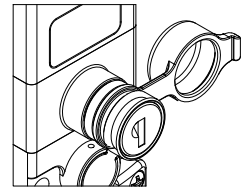

### 3.11 Switches internal connections



**Warning:** The device is provided with OSSD type solid-state safe electronic outputs. These outputs behave in a different way as compared to an electromechanical contact. The use and installation of a safety device with solid-state outputs are only allowed when all the characteristics of this particular type of outputs are known in detail.

To open the device cover, use a PH2 cross-head screwdriver and tighten the screws with a torque ranging from 0.8 to 1.2 Nm.

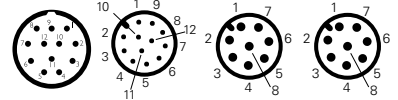
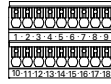

Internal terminal strip switch	Connections		M23 male connector 12 poles	M12 male connector 12 poles	M12 male connector 8 poles stand-alone connection	M12 male connector 8 poles connection in series with connectors type Y
	Code	Description				
1	A2	Power supply input 0 V	3	3	3	3
2	B2	Auxiliary power supply 0 V	3	3	3	3
3	I4	Solenoid activation input	10	10	8	8
4	O3	Signalling output for actuator switched on	5	5	2	/
5	O4	Signalling output for actuator switched on and locked (b)	9	9	5	5
6	I3	Actuator programming input	8	8	6	/
10	A1	Power supply input +24 Vdc	1	1	1	1
11	B1	Auxiliary power supply +24 Vdc, 8 A max	1	1	1	1
12	IS1	Safe input	2	2	/	2
13	IS2	Safe input	6	6	/	6
14	I5	EDM input (a)	11	11	/	/
15	OS1	Safe output	4	4	4	4
16	OS2	Safe output	7	7	7	7

Warning: terminals 7, 8, 9, 17 and 18 must not be used.

(a) Only available in version NG 2D\*\*5\*\*\*

(b) On the NG 2D\*\*6\*\*\* the output signals the FAULT status of the switch.

### 3.12 Internal wiring (version with built-in control devices)

The new switches' cover can be provided with one to three built-in control devices. Here below you will find the standard wirings for these devices. On demand, other configurations are available.



Internal terminal strip built-in control devices	Connections	
19	Contact 1	Device 1
20		
21	Contact 2	Device 2
22		
23	Contact 1	Device 3
24		
25	Contact 2	Device 1
26		
27	Contact 1	Device 2
28		
29	Contact 2	Device 3
30		
31	+24 Vdc supply input / LED Device 1	
32	+24 Vdc supply input / LED Device 2	
33	+24 Vdc supply input / LED Device 3	
34	0 V supply input / LED	

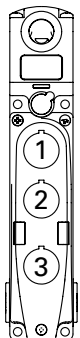

### 3.13 Switch with built-in control devices to be wired

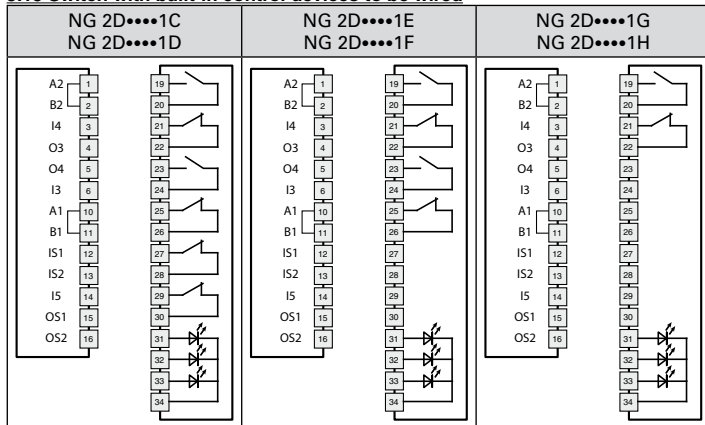

### 3.14 Switch with built-in control devices to be wired with M23 connector, 19 poles

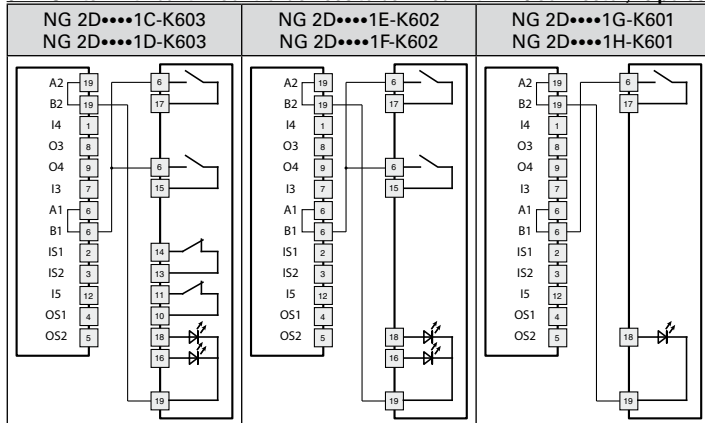

### 3.15 RFID sensor intervention points

The RFID sensor placed in the device recognises the actuator when it is found at a distance of 0 to 3 mm. Within this field, the O3 signalling output and the ACT led are activated to signal the guard-closed condition. In this condition, it is possible to obtain output locking by means of the I4 input. After the locking operation, the LOCK led and the O4 output are activated; at the same time the RFID sensor widens its releasing distance, so as to ensure that no vibrations or knocks occurring with the guard locked may cause the OS1, OS2 and O4 outputs to open accidentally. If the I4 input is activated or deactivated, without the actuator being present, the device does not carry out any locking and does not activate any of the OS1, OS2, or O4 outputs. In order to open the protection, it is necessary to act by means of the I4 input; with the protection released, the O4 output will be deactivated and the LOCK led will be switched off. At this point, the RFID sensor will bring its intervention distance back to the initial values and, after the guard has been opened, the O3 output and the ACT led will be deactivated.

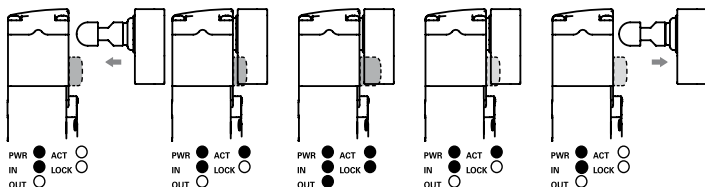

## 4 OPERATION

### 4.1 Definitions

State of the switch:

- OFF: the device is off, not powered.
- POWER ON: status immediately following switching on, when the device carries out internal tests.
- RUN: status in which the device works normally.
- ERROR: error status in which the safe outputs are deactivated. Indicates that a fault is present inside or outside the device, such as for example:
  - short circuit between the safe outputs (OS1 and OS2),
  - short circuit between a safe output and the earth,
  - short circuit between a safe output and the power supply voltage,
  - excessive misalignment between a switch and a locked actuator,
  - excess of maximum holding force with relating device breakage in the locked condition,
  - excess of maximum or minimum ambient temperature admitted,
  - internal fault.

Safety functions:

The safety functions are defined as follows:

- 1) The OSSD safety outputs must be de-activated when the guard is detected as unlocked (not available on 'Mode 2' versions).
- 2) The OSSD safety outputs must be de-activated when RFID tag is not detected anymore
- 3) The OSSD safety outputs must be de-activated when at least one safety input channel (IS1 or IS2) is not active.
- 4) The device must keep the guard closed and locked when electro magnet is active ('E' mode) or inactive ('D' mode) and applied force is lower than the declared F<sub>zh</sub> value.

EDM function (on selected versions). External Device Monitoring is a function that allows the device to monitor the state of external contactors. External contactors activation/deactivation state must follow NG switch OSSDs state within a maximum delay (see par. 4.7)

### 4.2 Operation description

Note: The following operation description refers to a device with safety outputs active on guard closed and locked (Mode 1). A device with safety outputs active on guard

closed (Mode 2) differs in the activation of the safety outputs OS1 and OS2 without the guard locking verification performed by function f4.

After being correctly installed by following the present instructions, the safety device can be supplied with power. The sequence below shows the logic functions which interact inside the safety device.

In the initial "POWER ON" status, function f0 of the safety device carries out an internal self-diagnosis which, if successfully completed, brings the device to the "RUN" status. If the test is not passed due to an internal fault, the device enters the "ERROR" status. On EDM versions, at power on, the EDM signal is checked and it must be active within 500 ms from device startup. In case the EDM positive signal is not present, after timeout the function f5 makes the device enter the fault state.

The "RUN" status indicates normal operation: function f1 evaluates the IS1 and IS2 inputs, while at the same time function f2 checks that the actuator is present, and function f4 checks that the actuator has been locked. On EDM versions, f5 checks the coherence of EDM signal during state changes and in the safe output off state. When these three conditions occur, function f3 of the device activates the OS1 and OS2 safe outputs.

The IS1 and IS2 inputs of the device are usually activated simultaneously and therefore they are monitored, in terms of their status and their coherence. The device de-activates the safe outputs and signals a condition of non-coherent inputs by means of IN led green/orange blinking light, in the case where only one of the two inputs is deactivated. In order to get the safe outputs to become newly active, both inputs must be deactivated, before being reactivated.

During the RUN status, function f0 cyclically carries out internal tests in order to highlight any faults. Any internal error being detected brings the device to the "ERROR" status (PWR led with red fixed light), which immediately deactivates the safe outputs. The "ERROR" status can be reached even in the case of short circuits occurring between the safe outputs (OS1 and OS2) or a short circuit of an output towards earth or towards the power supply. Also in this case, function f3 deactivates the safe outputs, and the error status is indicated by the OUT led red blinking light.

The O3 signalling output is activated during the "RUN" status when the actuator is inserted in the device, regardless of the status of this output is displayed by means of the ACT led.

The O4 signalling output is activated during the "RUN" status when the actuator has been inserted and locked inside the device, regardless of the status of the IS1 and IS2 inputs. The status of this output is displayed by means of the LOCK led.

The actuator locking and releasing operations are controlled by means of the I4 input.

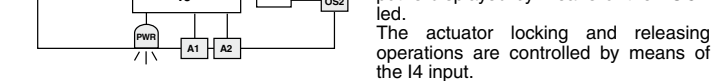

### 4.3 Actuator replacement

The I3 input can be used, at all times, to replace the coded actuator with a second actuator. By activating this input, the device gets ready for programming mode with the IN led orange light blinking, it deactivates all the OS1, OS2, O3 and O4 outputs and then releases the actuator. Keep the input active while inserting the second actuator. The completed acquisition of the second actuator will be confirmed by the IN led being switched off. At this point, it is possible to deactivate the I3 input. The device will automatically be brought to the restarting condition.

The first actuator will no longer be recognised.

The second actuator will have to be adequately fixed to the protection as explained in point 3.5.

This operation must not be carried out as a repair or maintenance operation.

In the case where the device stops working correctly, replace the entire device and not just the actuator.

### 4.4 Connection in series with safety modules

It is possible to install several devices in cascade connection up to a maximum number of 32 units, while maintaining safety category 4 / PL<sub>e</sub> according to EN ISO 13849-1 standard and SIL CL 3 integrity level according to EN 62061 standard.

Check that the PFH<sub>d</sub> and MTTF<sub>d</sub> values of the system comprising the device cascade, as well as the safety module, meet the SIL/PL level requirements prescribed for the application.

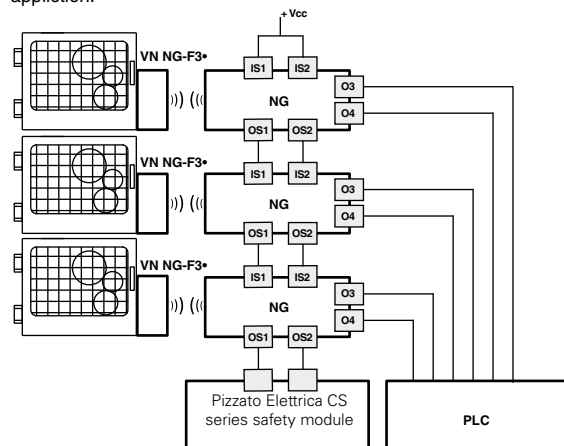

With this connection method, observe the following directions:

- Connect the inputs of the first device in the chain to the power supply.
- The OS1 and OS2 safety outputs of the last device in the chain must be evaluated by a safety module.
- Only use the device cascade with the safety modules which are compatible with the characteristics of the OS1/OS2 safe outputs. (See paragraph 4.6 - INTERFACING).
- Respect the limits on the output line stray capacity, as specified in the electrical data. (See paragraph 6.3.2 - ELECTRICAL DATA OF OS1/OS2 SAFE OUTPUTS).
- Check that the cascade response time respects the requirements of the safety function to be obtained.
- The chain response time must be calculated taking into account the response time of each device.

#### 4.5 Operation status: Mode 1 (safety outputs active on locked guard)

PWR LED	IN LED	OUT LED	ACT LED	LOCK LED	EDM <sup>a</sup>	Sensor status	Description
O	O	O	O	O	O	OFF	Device off.
green / alternated red	green / alternated red	green / alternated red	green / alternated red	green / alternated red	green / alternated red	POWER ON	Internal tests at switching on.
green	O	O	*	*	green	RUN	Device with safe outputs not active.
green	green	*	*	*	*	RUN	Activation of safe inputs.
green	green / orange blinking	O	*	*	*	RUN	Non-coherence of safe inputs. Recommended action: check for presence and/or wiring of inputs.
green	*	*	green	*	*	RUN	Actuator in safe area. O3 signalling output active.
green	*	*	green	green	O	RUN	Actuator in safe area and locked, O3 and O4 outputs active.
green	green	green	green	green	O	RUN	Activation of the IS1 and IS2 safe inputs. Actuator in safe area and locked, O3, O4 and safety outputs active.
green	*	red blinking	*	*	*	ERROR	Error on safe outputs. Recommended action: check for any short circuits between the outputs, outputs and earth or outputs and power supply, then restart the device.
green	O	O	red blinking	O	O	ERROR	Actuator detection error. Check for physical integrity of the device, if faulty replace the entire device. If undamaged, realign the actuator with the switch and restart the device.
red	O	O	O	O	O	ERROR	Internal error. Recommended action: restart the device. If the fault persists, replace the device.
green	*	O	*	*	green	RUN	EDM signal active (external relay OFF) <sup>a</sup>
green	green	green	green	green	O	RUN	EDM signal inactive (external relay ON) <sup>a</sup>
green	O	O	O	O	Red blinking	ERROR	Error in EDM function <sup>a</sup>

#### 4.6 Operation status: Mode 2 (safety outputs active on closed guard)

PWR LED	IN LED	OUT LED	ACT LED	LOCK LED	EDM <sup>a</sup>	Sensor status	Description
O	O	O	O	O	O	OFF	Device Off
green / alternated red	green / alternated red	green / alternated red	green / alternated red	green / alternated red	green / alternated red	POWER ON	Internal tests at switching on.
green	O	O	*	*	green	RUN	Device with safe outputs not active.
green	green	*	*	*	*	RUN	Activation of safe inputs.
green	green / orange blinking	O	*	*	*	RUN	Non-coherence of safe inputs. Recommended action: check for presence and/or wiring of inputs.
green	*	*	green	*	*	RUN	Actuator in safe area. O3 signalling output active
green	*	*	green	green	*	RUN	Actuator in safe area and locked, O3 and O4 outputs active.
green	green	green	green	*	O	RUN	Activation of the IS1 and IS2 safe inputs. Actuator in safe area, O3 and safety outputs active.
green	O	Red blinking	O	O	O	ERROR	Error on safe outputs. Recommended action: check for any short circuits between the outputs, outputs and earth or outputs and power supply, then restart the device.
green	O	O	Red blinking	O	O	ERROR	Actuator detection error. Check for physical integrity of the device, if faulty replace the entire device. If undamaged, realign the actuator with the switch and restart the device.
red	O	O	O	O	O	ERROR	Internal error. Recommended action: restart the device. If the fault persists, replace the device.
green	*	O	*	*	Green	RUN	EDM signal active (external relay OFF) <sup>a</sup>
green	green	green	green	green	O	RUN	EDM signal inactive (external relay ON) <sup>a</sup>
green	O	O	O	O	Red blinking	ERROR	Error in EDM function <sup>a</sup>

O = off  
\* = indifferent

(a) Only available in version NG 2D\*\*51A.

#### 4.7 Interfacing

##### Connections with CS AR-08\*\*\* safety modules

Input configuration with monitored start  
2 channels / Category 4 / up to SIL 3 / PL e

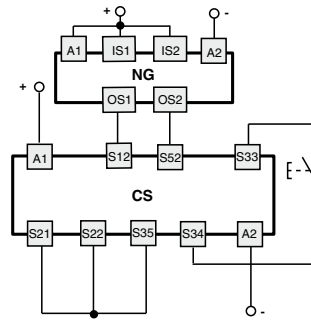

##### Connections with CS AR-05\*\*\* / CS AR-06\*\*\* safety modules

Input configuration with manual start (CS AR-05\*\*\*)  
or monitored start (CS AR-06\*\*\*)

2 channels / Category 4 / up to SIL 3 / PL e

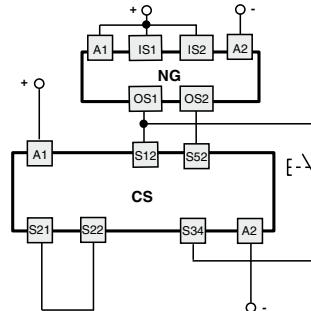

##### Connections with CS AT-0\*\*\* / CS AT-1\*\*\* safety modules

Input configuration with monitored start

2 channels / Category 4 / up to SIL 3 / PL e

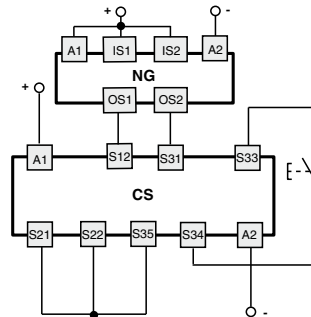

##### Connections with CS MF\*\*\*0, CS MP\*\*\*0 safety modules

Connections change depending on the module program

Category 4 / up to SIL 3 / PL e

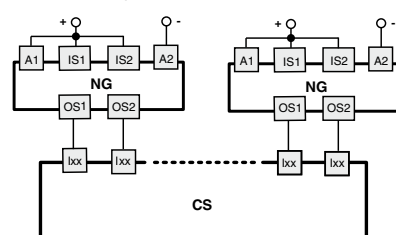

##### Connections with EDM

Category 4 / up to SIL 3 / PL e

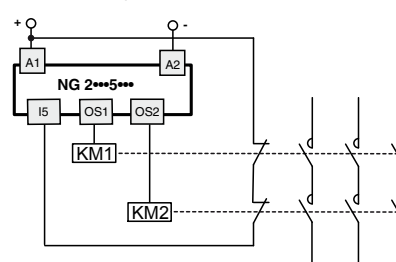

## 5 DIRECTIONS FOR CORRECT DEVICE USE

### 5.1 Installation

 **Warning:** The installation must exclusively be carried out by qualified personnel. The OS1 and OS2 safe outputs of the device must be connected to a safety module (or safety PLC) for their supervision. The O3 and O4 signalling outputs are not safe outputs and cannot be used individually in a safety circuit to determine the safe guard-closed status.

- Do not deform or modify the device for any reason whatsoever.
- Do not exceed the tightening torques specified in the present manual.
- The device carries out an operator protection function. Any inadequate installation or tampering can cause people serious injuries and even death.
- These devices must neither be avoided (for example by bridging the contacts), nor removed, nor turned or made inefficient in any other way.
- If the machine where the device is installed is used for a purpose other than that specified by the producer, the switch may not provide the operator with efficient protection.
- Before commissioning the machine and also periodically, check for correct switching of the outputs and correct operation of the system comprising the device and associated safety module.
- The safety category of the system comprising the safety switch also depends on external devices and their connection.
- Before installation, make sure that each part of the device is intact.
- Before installation, ensure that the connection cables are not powered.
- Avoid excessive bending of connection cables in order to prevent any short circuits or power failures.
- Do not paint or varnish the device.
- Do not perforate the device; to insert electrical cables only use one of the three M20x1.5 threaded cable inlets found in the device. Do not use the device as a support or rest for other structures, such as raceways sliding guides or similar.
- Before setting at work, make sure that the entire machine or system complies with all applicable standards and EMC directive requirements.
- Do not apply excessive force on the device, after the actuator has been fully inserted.
- The switch fitting surface must always be smooth and clean.
- The documentation needed for correct installation and maintenance is always available in the following languages: English, French, German and Italian.
- Should the installer be unable to fully understand the documentation, the product must not be installed and the necessary assistance may be requested (See paragraph 9 - SUPPORT).
- When the device is installed on a mobile frame and the actuator is installed on a mobile door, ensure that the device cannot be damaged by simultaneous opening of the frame and the door.
- After installation, check for correct operation of the auxiliary release (if present) and the anti-panic release button (if present).
- Always keep the present operation directions enclosed with the manual of the machine to which the device is fitted.
- The present operation directions must be kept in such a way as to be readily available during the entire period when the device is used.

### 5.2 Not to be used in the following types of environment

- An environment where continuous temperature changes cause condensation inside the device.
- An environment where the application causes the device to be subject to strong impact or vibration.
- An environment where explosive or flammable gases are present.
- An environment where the device may become coated with ice.
- An environment containing strongly aggressive chemicals, where the products coming into contact with the device may impair its physical or functional integrity.
- An environment where contaminated agents can get in the hole found in the switch head and be deposited inside, which can lead to sealing gasket damage, can stop the fixing pin from sliding or damage it.

### 5.3 Mechanical stop

- Even if the switch is provided with a rubber bumper positioned between the actuator and the switch, the door must always be provided with an independent end-limit mechanical stop on closing. All that to protect the device from being knocked when the door is slammed hard.
- Do not use the switch as a mechanical door stop.

### 5.4 Knocks, vibrations and wear

- In case of any damage or wear, the entire device with actuator must be replaced.
- Avoid any collision with the device. Knocks and excessive vibrations may fail to guarantee correct device operation.

### 5.5 Maintenance

 **Warning:** Do not disassemble or try to repair the device. In case of any malfunction or fault, replace the entire device.

 **Warning:** Correct operation cannot be guaranteed when the device is deformed or damaged.

The installer is responsible for establishing the sequence of functional tests to which the installed device is to be subject for complete maintenance. The testing sequence can vary according to machine complexity and circuit diagram, therefore the functional test sequence detailed below is to be considered as minimal and not exhaustive.

At least once a year or after prolonged stoppage, carry out the following checking operations.

- 1) Lock the protection and start the machine. It must be impossible for the protection to be opened.
- 2) With the machine stationary and the protection open, the machine must not be allowed to start.
- 3) When the anti-panic release button (if fitted) is pressed, the protection must open freely and the machine must not start. Each time the release button is activated, the machine must stop and the door must open immediately. The release button must slide freely, without sticking, and be tightly screwed in. The signs placed inside the machine, indicating the function of the release button (if fitted), must be intact, clean and clearly readable.
- 4) With the protection closed but not locked, the machine must not be allowed to start (not applicable to safety output activation mode 2, see par. 3.3).
- 5) All external parts must be undamaged.

6) If the device is damaged, replace it completely.

7) The actuator must be securely locked to the door, make sure that none of the machine operator's tools can be used to disconnect the actuator from the door.

8) The device has been created for applications in dangerous environment, therefore its operation is limited over time. 20 years after its production date, the device must be totally replaced, even when still working. The production date is found next to the product code (See paragraph 5.10 – MARKING)

### 5.6 Precautions during wiring

- Check that the power supply is correct before supplying the device with power.
- Keep the load within the values specified in the electrical operation categories.
- Disconnect the power supply before accessing the device connections.
- Only connect and disconnect the device when the power is off.
- Do not open the internal device cover under any circumstances.
- Discharge static electricity before handling the product, by making contact with a metal mass connected to earth. Any strong ESD discharge could damage the device.
- Power the safety switch and other connected devices from one single SELV-type source and in conformity with the relevant standards.
- Always connect the protection fuse (or equivalent device) in series with the power supply for each device (See paragraph 6.3 – ELECTRICAL DATA).
- The device contains two PUSH-IN spring-operated terminal boards for connecting the following electrical leads:

Cross section of solid leads or leads with tips min. 0.34 mm<sup>2</sup> (AWG 22) max. 1.5 mm<sup>2</sup> (AWG 16).

Cross section of leads with pre-insulated tips min. 0.34 mm<sup>2</sup> (AWG 22) max. 0.75 mm<sup>2</sup> (AWG 18).

Stripping length of electrical leads: min. 8 mm - max. 12 mm

### 5.7 Additional prescriptions for safety applications with personal protection functions

Provided that all previous requisites are fulfilled, when the devices installed are intended to ensure personal protection, the following additional prescriptions are also to be observed:

- In all cases, device operation implies the knowledge and observance of the following standards: EN 60947-5-3, EN ISO 13849-1, EN 62061, EN 60204-1, EN ISO 14119, EN ISO 12100.
- Correct operation of safety devices must be checked periodically, at intervals established by the machine manufacturer according to the machine danger level, and in any case must be checked at least once a year.

### 5.8 Limitations of use

- The device can be used as a component within a system having safety category 4 / PL e according to EN ISO 13849-1 standard and integrity level SIL CL 3 according to EN 62061 standard.
- Use the device by following the instructions, keeping to its operating limits and respecting the current safety standards.
- The devices have specific application limitations (minimum and maximum ambient temperature, mechanical working life, protection degree etc.). These limitations are met by the device only if considered individually and not as combined with others.
- The manufacturer's liability is to be excluded in the following cases:
  - Use not conforming to the intended purpose.
  - Failure to observe safety instructions.
  - Fitting operations not carried out by qualified and authorized personnel.
  - Omission of functional tests.
- For the cases listed below, contact our assistance service (See paragraph 8 - SUPPORT):
  - Nuclear power stations, trains, airplanes, motorcars, incinerators, medical appliances or any other applications where the safety of two or more persons depends on correct device operation.
  - Cases not mentioned on the instruction sheet.

### 5.9 Functional tests before commissioning the device

The device installer is responsible for establishing the sequence of functional tests to which the installed device is to be subject before machine commissioning. The testing sequence can vary according to machine complexity and circuit diagram, therefore the functional test sequence detailed below is to be considered as minimal and not exhaustive.

- 1) Lock the protection and start the machine. It must be impossible for the protection to be opened.
- 2) With the machine stationary and the protection open, the machine must not be allowed to start.
- 3) When the escape release button (if fitted) is pressed, the protection must open freely and the machine must not start.
- 4) When the auxiliary release (if fitted) is activated, the protection must open freely and the machine must not start.
- 5) With the protection closed but not locked, the machine must not be allowed to start (not applicable to safety output activation mode 2, see par. 3.3).
- 6) The actuator must be securely locked to the door; make sure that none of the machine operator's tools can be used to disconnect the actuator from the door.

### 5.10 Marking

The outside of the device is provided with marking positioned in a visible place.

Marking includes:

- Producer trademark
- Product code
- Batch number and production date. Example: A14 NG1-411. The first character of the batch indicates the production month (A=January, B=February etc...). The second and third characters indicate the production year (14=2014, 15=2015 etc...).



## 6 TECHNICAL DATA

### 6.1 Housing

Metal housing, with powder coating.  
Three M20x1.5 threaded cable inlets  
Protection degree:

IP67 according to EN 60529  
IP69K according to ISO 20653

Degree of protection with control devices:  
with cable gland (or other equivalent connection system) having equal or higher protection degree

### 6.2 General data

SIL (SIL CL) level: up to SIL 3 according to EN 62061  
up to PL e according to EN ISO 13849-1  
Performance Level (PL):  
Safety category: up to 4 according to EN ISO 13849-1  
Interlocking with lock, with non-contact, coded: type 4 according to EN ISO 14119  
Coding level according to EN ISO 14119:

low level with F30 actuator  
high level with F31 actuator

PFH<sub>g</sub>: 8.07 E-10  
MTTF<sub>a</sub> (single channel): 1883 years  
DC: High  
Mission time: 20 years  
Ambient temperature: from -20°C to +50°C  
Storing temperature: from -40°C to +75°C  
Maximum operation altitude: 2000 m  
Time for starting the switching operation: 2 s

Maximum activation frequency with actuator lock and release: 600 operation cycles/hour  
Mechanical life: 1 million operation cycles

Maximum activation speed: 0.5 m/s  
Minimum activation speed: 1 mm/s  
Fitting position: any  
Maximum force before breakage F<sub>1max</sub>: 9750 N according to ISO 14119  
Maximum holding force F<sub>2h</sub>: 7500 N according to ISO 14119  
Play of locked actuator: 4 mm  
Extraction force of released actuator: 30 N

### 6.3 Electrical data

Rated operation voltage U<sub>e</sub>: 24 Vdc ±10% SELV  
Operation current at U<sub>e</sub> voltage:  
- minimum: 40 mA  
- with electromagnet activated: 0.4 A  
- with electromagnet activated and all outputs at maximum power: 1.2 A  
Rated insulation voltage U<sub>i</sub>: 32 Vdc  
Rated impulse withstand voltage U<sub>imp</sub>: 1.5 kV  
External protection fuse: 1.5 A / 1.6 A type F or equivalent device  
Overvoltage category: III  
Electrical life: 1 million operation cycles  
Solenoid insertion ratio: 100% ED  
Electromagnet consumption: 9 W  
Pollution degree: 3 according to EN 60947-1

#### 6.3.1 Electrical data for IS1/IS2/I3/I4/I5/EDM inputs

Rated operation voltage U<sub>e1</sub>: 24 Vdc  
Rated absorbed current I<sub>e1</sub>: 5 mA

#### 6.3.2 Electrical data for OS1/OS2 safe outputs

Rated operation voltage U<sub>e2</sub>: 24 Vdc  
Type of output: PNP type OSSD  
Maximum current per output I<sub>e2</sub>: 0.25 A  
Minimum current per output I<sub>m2</sub>: 0.5 mA  
Thermal current I<sub>m2</sub>: 0.25 A  
Category of use: DC13; U<sub>e2</sub>=24 Vdc, I<sub>e2</sub>=0.25 A  
Short-circuit detection: Yes  
Protection against overcurrent: Yes  
Internal self-resetting protection fuse: 1.1 A  
Time for deactivation impulses on safe outputs: <300 μs  
Capacity admitted between output and output: <200 nF  
Capacity admitted between output and earth: <200 nF  
Response time for OS1 and OS2 safe outputs on input deactivation:  
• Typical 7 ms  
• Maximum 15 ms  
Response time on door release:  
• Typical 7 ms  
• Maximum 12 ms  
EDM input signal state change maximum delay: 500 ms

#### 6.3.3 Electrical data for O3/O4 signalling outputs

Rated operation voltage U<sub>e3</sub>: 24 Vdc  
Type of output: PNP  
Maximum current for Ie output I<sub>e3</sub>: 0.1 A  
Category of use: DC12; U<sub>e3</sub>=24 Vdc, I<sub>e3</sub>=0.1 A  
Short-circuit detection: No  
Protection against overcurrent: Yes  
Internal self-resetting protection fuse: 1.1 A

#### 6.3.4 RFID sensor data

Assured intervention distance s<sub>ao</sub>: 2 mm  
Assured releasing distance s<sub>ar</sub>: 4 mm (actuator not locked)  
10 mm (actuator locked)  
Rated intervention distance s<sub>n</sub>: 2.5 mm  
Repeatability precision: ≤10% s<sub>n</sub>  
Differential travel: ≤20% s<sub>n</sub>  
Maximum switching frequency: 1Hz  
Minimum distance between 2 identical devices to avoid reciprocal radio interferences: 2 mm

### 6.4 Conformity with the following standards:

EN ISO 14119, EN 60947-5-3:2013, EN 60947-1, EN 60204-1, EN ISO 12100, EN 60529, EN 61000-6-2, EN 61000-6-3, BG-GS-ET-19, IEC 61508:2010, SN 29500, EN ISO 13849-1:2008, EN ISO 13849-2:2012, EN 62061:2005+EC:2010+A1:2013, EN 61326-1, EN 61326-3-1, EN 61326-3-2, ETSI 301 489-1, ETSI 301 489-3, ETSI 300 330-2, UL 508, CSA 22.2 No.14

### 6.5 Conforming to the requirements prescribed by:

2006/42/EC Machine Directive  
2014/30/EC Electromagnetic compatibility  
Directive 2014/53/EC - RED  
FCC Part 15 Statements: This device complies with part 15 of the FCC Rules. Operation is subject to the following two conditions: (1) This device may not cause harmful interference, and (2) this device must accept any interference received, including interference that may cause undesired operation.

## 7 TECHNICAL DATA (BUILT-IN CONTROL DEVICES)

### 7.1 Housing

Protection degree: IP65 acc EN 60529  
Mechanical endurance:  
Spring-return button: 1 million operating cycles  
Emergency buttons: 50,000 operating cycles  
Selector: 300,000 operating cycles  
Key selector: 50,000 operating cycles  
30,000 operating cycles with key extraction

### 7.2 Actuating force

Spring-return button: 4 N min 100 N max  
Emergency buttons: 20 N min 100 N max  
Selector: 0.1 Nm min 1.5 N max  
Key selector: 0.1 Nm min 1.3 N max

### 7.3 Contact blocks:

Contact material: silver contacts  
Contact design: self-cleaning contacts with double support point

### 7.4 Electrical data:

Thermal current I<sub>th</sub>: 1 A  
Rated insulation voltage U<sub>i</sub>: 32 Vac/dc  
Rated impulse withstand voltage U<sub>imp</sub>: 1.5 kV  
LED Rated operating voltage: 24 Vdc ± 15%  
LED Rated operating current: 10 mA each LED

### 7.5 Utilization category:

Direct current: DC13  
U<sub>e</sub> (V) 24  
I<sub>e</sub> (A) 0,55

### 7.6 In conformity with standards:

IEC 60947-5-1, IEC 60947-5-5, EN ISO 13850

## 8 SPECIAL VERSIONS ON REQUEST

Special versions of the device are available on request.  
These special versions may differ substantially from the indications in this instruction sheet.

The installer must ensure that he has received written information from the support service regarding use of the special version requested.

## 9 DISPOSAL

At the end of service life product must be disposed of properly, according to the rules in force in the country in which the disposal takes place.

## 10 SUPPORT

The device has been created for safeguarding people's physical safety, therefore in case of any doubt concerning installation or operation methods, always contact our technical support service:

Pizzato Elettrica Srl - Italy  
Via Torino, 1 - 36063 Marostica (VI)  
Telephone +39.0424.470.930  
Fax +39.0424.470.955  
E-mail tech@pizzato.com  
www.pizzato.com  
Our support service provides assistance in Italian and English.

## 11 EC CONFORMITY DECLARATION

I, the undersigned, as a representative of the following manufacturer:  
Pizzato Elettrica s.r.l., Via Torino, 1 - 36063 Marostica (VI) - Italy  
hereby declare that the product is in conformity with whatever prescribed by the 2006/42/EC Machine Directive. The complete version of the present conformity declaration is available on our site www.pizzato.com  
Mr. Pizzato Giuseppe

### DISCLAIMER:

Rights to any modifications reserved without prior notice and errors excepted. The data mentioned on this sheet are accurately checked and represent typical mass production values. All descriptions of the device and its applications, work contexts, details on external testing, information on installation and operation are supplied according to our best knowledge. However, this does not mean that the characteristics described may entail legal liabilities extending beyond the "General Terms of Sale", as stated in the Pizzato Elettrica general catalogue. Customers/users are not exempt from the obligation to examine our information and recommendations, as well as the relevant technical standards, before using the products for their own purpose. Taking into account the great variety of applications and possible connections of the device, the examples and diagrams given in the present manual are to be considered as merely descriptive; the user is deemed responsible for checking that the specific application of the device complies with current standards. This document is a translation of the original instructions. In case of discrepancy between the present sheet and the original copy, the Italian version shall prevail. The present manual may not be reproduced, in whole or in part, without the prior written permission by Pizzato Elettrica. All rights reserved.